

**ROTEL**®

**RT-620**

**AM - FM STEREO TUNER**

## INTRODUCTION

We would like to take this opportunity to thank you for purchasing our ROTEL RT-620 AM/FM STEREO TUNER. In RT-620 you have the finest equipment available in the Hi-Fi components field. With the quality workmanship that goes into making the RT-620, you can be assured of its flawless performance for many years to come.

The RT-620 is equipped with every conceivable control and feature any demanding audiophile ever hopes of having on his unit. The RT-620 was designed for both the versatility and ease of operation. It will add professional studio flexibility to your present music center.

The performance of RT-620 is exceptional; it will allow you to experience true high fidelity as never before. Its full and natural stereophonic reproduction offers you musical entertainment rivaling that of live performances. We sincerely hope you will treasure this professional equipment.

In order to obtain the maximum use out of your unit, please read all of the following pages of this Operation Manual carefully.

Do not attempt to operate the unit until you have made all the connections as specified in this Manual.

## SPECIAL FEATURES

- 1) FM Section: FET Front-End,  
4-Gang Variable Capacitor,  
2-Stage RF Amplifier,  
Ceramic Filters,  
Variable Muting Control.
- 2) AF Section: 3-Gang Variable Capacitor,  
1-Stage RF Amplifier,  
Ceramic Filters.
- 3) Variable AM and FM Output Levels.
- 4) Noise Filter.
- 5) AM-FM Dual Illuminated Tuning Meter.
- 6) Stereo Indicator Light.
- 7) Illuminated Dial Pointer.
- 8) Control Knobs: Variable Muting Level and Tuning.
- 9) Push Buttons: Power, AM, FM, FM Stereo, Noise Filter and Muting.
- 10) Handsome Wood Cabinet.

# INSTALLATION

## IMPORTANT

Before attempting to operate the RT-620, please read the following instructions carefully. When all the necessary connections are made as specified, the power may be applied.

## AM LOOPSTICK ANTENNA

The RT-620 is equipped with a built-in ferrite loopstick antenna for AM reception. With the high sensitivity of the RT-620, loopstick antenna assures more than adequate reception of most local AM stations.

NOTE: The AM Loopstick Antenna is mounted on a swivel bracket. To obtain maximum effectiveness, carefully pull the antenna bar up and away from the chassis and leave it in extended position.

## AM OUTDOOR ANTENNA

If you are in a fringe area, far away from stations or in a high noise area such as near a highway or airport, an outdoor antenna is required to assure best reception. To utilize an outdoor antenna, simply connect the antenna lead to the terminal designated AM ANTENNA on the back panel.

## FM ANTENNA

The high sensitivity and selectivity of the RT-620 provide excellent FM reception in most areas with nothing more than a piece of wire about 48 inches in length as an FM antenna. Use the 48" wire antenna that is provided with the RT-620, and connect it to either of the FM antenna terminals. Horizontal placement of the antenna will usually yield optimum reception.

In difficult reception areas, such as an area with tall mountains or buildings that block or echo the signals, however, an outdoor antenna is recommended. To use an outdoor antenna, connect the antenna leads to the terminals designated FM ANTENNA 300 ohm on the back panel.

## GROUND

Although it is not necessary to do so, but if you wish to ground the RT-620, connect a wire from the terminal designated GND on the panel to the Ground terminal on your amplifier.

## OUTPUT

There are two pairs of Output Jacks designated LEFT and RIGHT on the back panel. The right hand pair is a standard, non-variable output. It is for use with most standard amplifiers. The LEFT and RIGHT Outputs on the RT-620 should be connected to the corresponding Left and Right Input (Tuner) jacks on your amplifier. Connecting Cables for this purpose are supplied with the RT-620. Make sure that the LEFT Output on the RT-620 is connected to the Left Input on your amplifier and likewise for the RIGHT Output.

The left hand pair is a variable output whose output level can be varied from 0 output to 0.3 V (30%, 400 Hz) for AM and from 0 to 1.5 V (100%, 400 Hz) for FM with the knob marked VARIABLE on the left hand side. This Output is for use with amplifiers whose input level requirements are different from the standard amplifiers. The VARIABLE knob at its left most position is 0 output. Turning it to the right will increase the output level proportionately, and at its right most position, the output level will be at maximum (same level as that for standard output).

To achieve appropriate output level for your amplifier's input requirements, set the VARIABLE knob to the position where the sound from the speakers is equally loud as when a record player is played through your amplifier (with, of course, the volume setting set at the same level).

## AC POWER INPUT CORD

Your RT-620 has been specially designed so that it may be connected to a variety of power sources. You may connect the AC Power Input Cord directly to a wall plug, in which case the power will be supplied to the RT-620 independent of your amplifier, or you may connect it to your amplifier's switched or unswitched AC outlets. If it is connected to a switched outlet, by leaving the POWER button on the RT-620 in its "IN" position, you will be able to maintain switching control for the RT-620 with your amplifier, and if it is connected to an unswitched outlet, like connecting to a wall outlet, you must use the RT-620's own POWER button for switching control.

## AC OUTLET

The RT-620 is equipped with an AC Outlet (switched) to provide switching control and power to whatever component you may wish to connect to the RT-620.

# INTERCONNECTING DIAGRAM

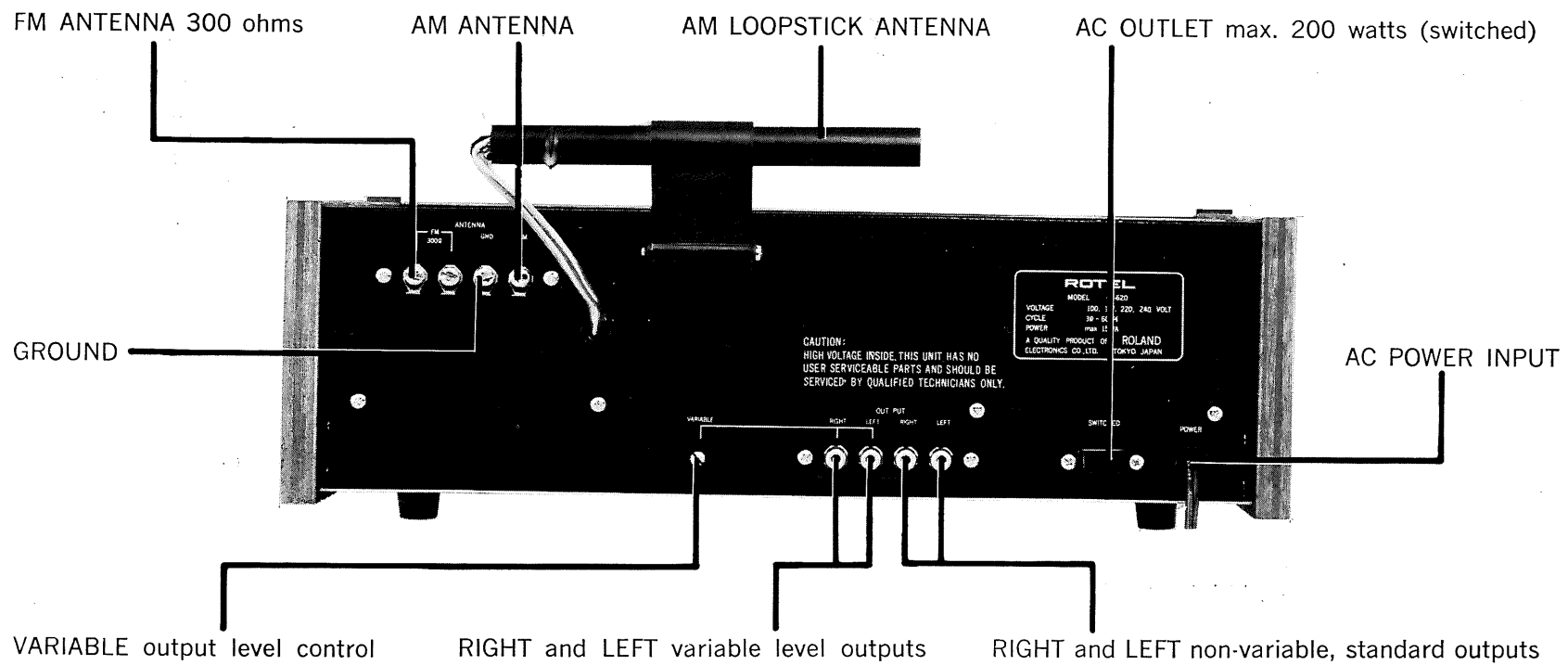

## OPERATION

When all the connections have been made according to the preceding instructions, you may apply the power by pushing "IN" the POWER button.

If you have connected the AC Power Cord to your amplifier's Switched Outlet, turning the RT-620 on or off may be done with the controls on your amplifier, in which case you should leave the POWER button on the RT-620 always in the "IN" position.

If you have connected the AC Power Input Cord to your amplifier's Unswitched Outlet or directly to a wall plug, each time you wish to operate the RT-620 you must push "IN" the POWER button independent of the controls on your amplifier.

## AM RECEPTION

To listen to an AM broadcast, push the AM FUNCTION button "IN". Select a desired station by adjusting the TUNING KNOB.

Your RT-620 is provided with a TUNING METER which measures the strength of a radio signal; thus, to achieve the best possible reception of a station, adjust the TUNING KNOB until you get maximum Meter deflection (to the right) on the AM Scale.

## FM RECEPTION

To listen to an FM broadcast, push the FM FUNCTION button "IN". Select a desired station by adjusting the TUNING KNOB.

To achieve the best possible reception of a station, adjust the TUNING KNOB until you get dead-center (on the middle square) reading on the FM Scale of the TUNING METER.

When the FM FUNCTION button is pushed, reproduction is limited to monophonic. This is so that whenever you are receiving a particularly poor FM stereo broadcast, degraded badly with noise, you may increase its reception by listening monophonically.

## FM STEREO RECEPTION (MULTIPLEX)

To listen to an FM Stereo broadcast, push "IN" the FM STEREO FUNCTION button. When you have tuned in on an FM Stereo broadcast, the STEREO INDICATOR LIGHT will automatically light up "STEREO".

NOTE: Your RT-620 is equipped with an Electronic Switching Circuit that automatically switches the unit to FM Stereo from Mono whenever an FM Stereo broadcast of sufficient signal strength is tuned in. The FM FUNCTION button,

however, in the "IN" position defeats the automatic switching function; so, unless you wish to specifically defeat the FM Stereo-Mono Automatic Switching and listen to an FM Stereo broadcast in mono, always leave the FM STEREO FUNCTION button in the "IN" position for both monophonic and stereophonic reproduction.

## NOISE FILTER

Whenever you have tuned in on a station with objectionable amount of noise mixed in with the signal, you may push "IN" the NOISE FILTER button to reduce this extraneous noise. This button, however, should not be pushed "IN" unless it is necessary; in other words, do not always leave this button in the "IN" position regardless of the noise level.

## MUTING

Whenever you tune for an FM broadcast, you will hear rather loud interstation noise; this is normal for all FM tuners and is not peculiar to your RT-620.

To reduce this bothersome interstation noise, your RT-620 is equipped with a unique Muting control. Muting is effected by pushing "IN" the MUTING button, but the level of muting may be varied to suit your purpose by adjusting the MUTING LEVEL knob. Muting is adjustable from  $3\mu\text{V}$  muting at the left most position of the knob to the maximum muting ( $20\mu\text{V}$ ) at the right most position.

If you wish to tune in a weak station, set the MUTING LEVEL at relatively low position so that muting will not suppress the weak signals. For tuning in strong stations, the MUTING LEVEL may be set at maximum.

The MUTING button should normally be turned OFF when you have tuned in the desired station, but it may be left ON without causing perceptible effect upon program reproduction. Again, however, if you have tuned in a weak station, the MUTING button should definitely be turned OFF to assure strongest possible signal reception.

## VOLTAGE SELECTION

Your RT-620 comes preset at the proper voltage for use in your area; however, if you move to an area where the power supply voltage is different, simply change the voltage setting. The RT-620 is a variable voltage tuner that can run on 100 V, 117 V, 220 V and 240 V power supplies. It is advisable to have your local Service Man do this, but if that is not possible, follow the instructions below.

To change the voltage setting, remove the bonnet cover and locate the Voltage Selector (CAUTION: Be sure to disconnect your unit from the power source before attempting to remove the bonnet cover). The Voltage Selector Plug has a white arrow on its top. Reinsert the Voltage Selector Plug so that the arrow lines up with the Pointer Line of the voltage you desire.

## CONTROLS AND THEIR FUNCTIONS

**ILLUMINATED DIAL POINTER** for easy tuning.

**TUNING METER** indicates the strength of the signal being received. It is used to tune for best possible reception of both AM and FM broadcasts.

**STEREO INDICATOR LIGHT** automatically lights up "STEREO" to indicate whenever the tuner is tuned to an FM Stereo broadcast.

**TUNING KNOB** allows you to tune for whatever AM or FM station you wish to hear.

**FM** in "IN" position limits the tuner to FM monophonic reproduction only.

**AM** in "IN" position is for AM monophonic program material.

**POWER** in "IN" position activates the tuner.

**FM STEREO** in "IN" position allows the tuner to reproduce FM stereo or mono, depending upon the program material.

**NOISE FILTER** allows you to suppress excessive extraneous noise. It effectively removes high frequency noise without affecting the program material.

**MUTING** allows you to activate or deactivate the muting control for interstation noise.

**MUTING LEVEL** allows you to adjust the level of muting to your preference, from  $3\mu\text{V}$  to  $20\mu\text{V}$ .

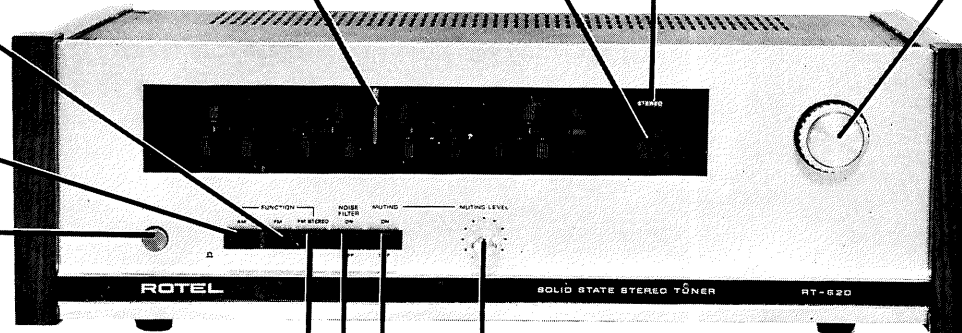

## SPECIFICATIONS

### FM SECTION:

Frequency Range:	88 — 108 MHz.
Antenna Impedance:	300 ohms balanced, 70 ohms unbalanced.
Sensitivity (IHF):	1.7 microvolts.
Harmonic Distortion:	less than 1 %.
Signal to Noise Ratio:	65 dB.
Image Rejection:	100 dB.
IF Rejection:	100 dB.
Spurious Response:	100 dB.
Capture Ratio:	1.5 dB
Selectivity (IHF):	60 dB.
Stereo Separation:	38 dB at 1 kHz.

### AF SECTION:

Frequency Range:	535 — 1605 kHz.
Sensitivity:	15 microvolts.
Image Rejection:	75 dB at 1 MHz.
IF Rejection:	75 dB at 1 MHz.
Signal to Noise Ratio:	50 dB.

**POWER VOLTAGE:** AC 100, 117, 220, 240 volts, 50/60 Hz.

**DIMENSIONS:** 16 1/4" (W) x 9 1/2" (D) x 4 7/8" (H).

**WEIGHT:** 11 lbs.

# SCHEMATIC DIAGRAM

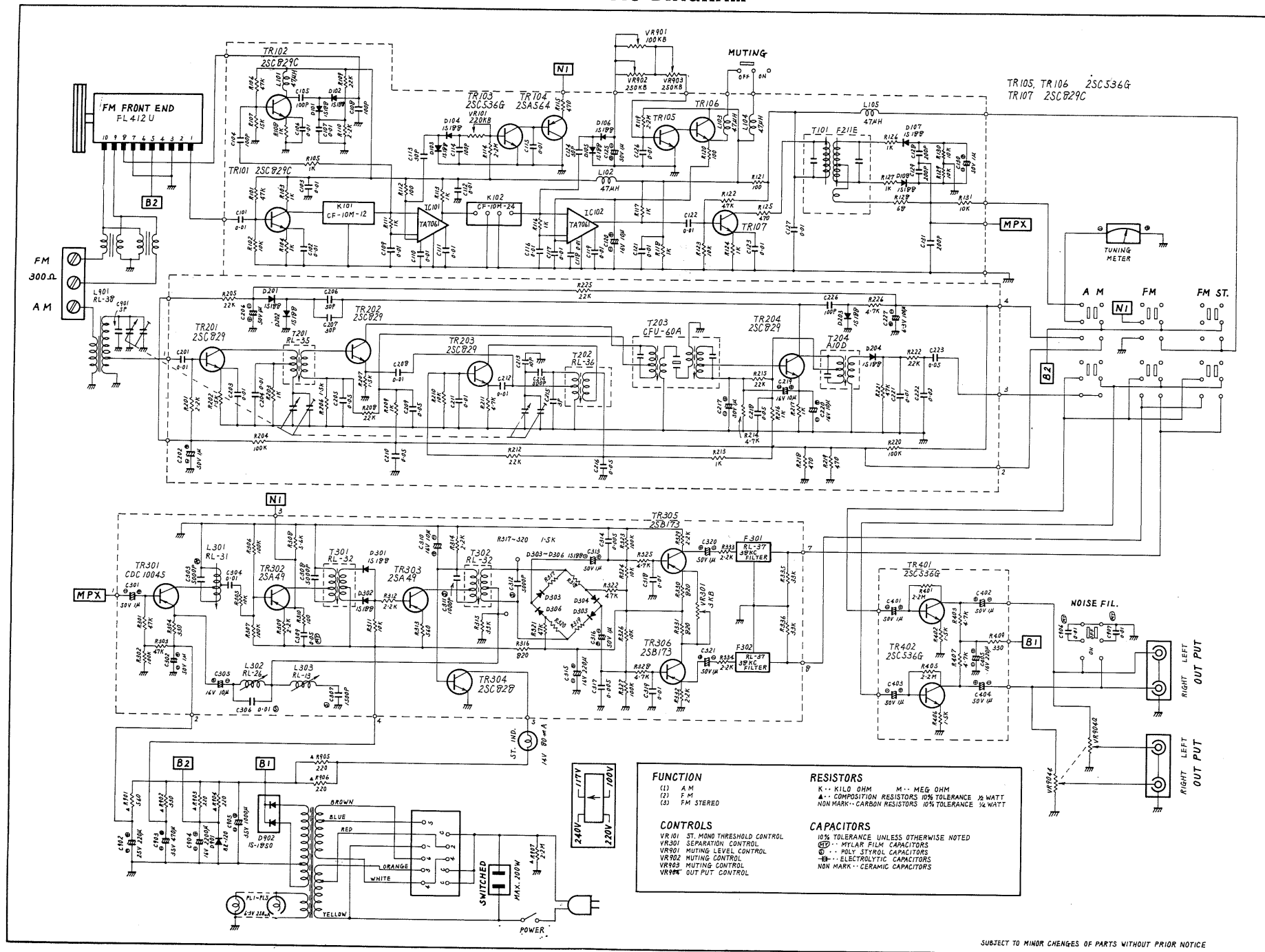



**. . . AND A FINE SUGGESTION FROM ROTEL:**

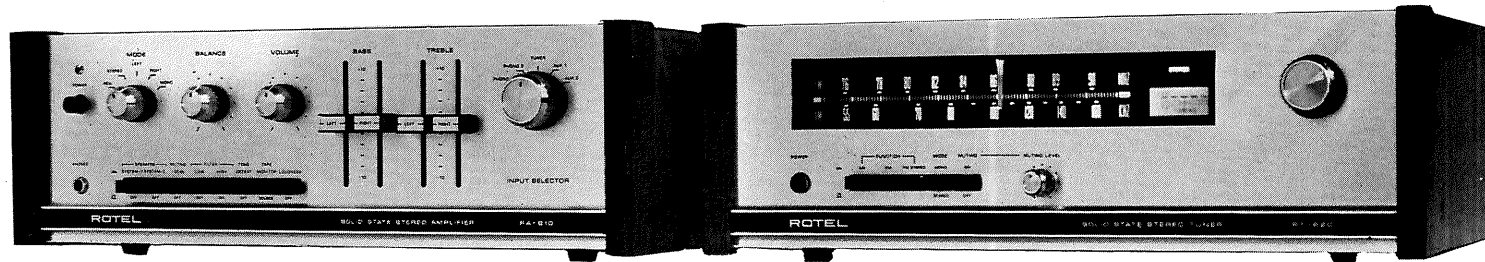

**RA-610 STEREO PRE-MAIN AMPLIFIER**

**RT-620 AM/FM STEREO TUNER**

In RT-620 you have made a fine choice of AM/FM STEREO TUNER from today's proliferating, often confusing, variety of Hi-Fi components that are available to the consumer. But if it is difficult to distinguish an excellent tuner, it is even more difficult to select an amplifier that is not only superior in itself but is truly suited to the tuner. Every tuner, including the RT-620, has its own unique characteristic, and for the RT-620 we cannot suggest to you a more fitting amplifier than the ROTEL RA-610 Stereo Pre-main Amplifier. The RT-620 and RA-610 were designed specifically to complement each other's characteristics and, hence, enhance each other's performance as no other combination of components can.

Some of RA-610's outstanding features:

- 1) Direct Coupling Output Circuit eliminates the need for an output capacitor, thereby, permitting better frequency response at lower IM distortion.
- 2) Differential Amplifier provides higher stability and lower distortion.
- 3) Split Power Supplies for left and right channels decrease frequency damping factor and overall distortion.
- 4) Tone Defeat switch offers absolute flat response.
- 5) - 20 dB Muting switch provides instantaneous quietness.
- 6) High and Low Filter switches, - 9 dB cutoff, for eliminating rumble and scratch noises.
- 7) Loudness switch for boosting extreme low frequencies during low volume operation.
- 8) Two pairs of magnetic input jacks for two sets of record players with different input impedances.
- 9) Pre-amplifier Outputs for use with separate power amplifier or multi-channel system, and Main-amplifier Inputs for use with separate control amplifier or tape recorder.